

HYUNDAI
POWER PRODUCTS

Gasoline Tiller

HMTB52-1

HMTB5255-3

HMTB6855-3

HMTB8365-3

ORIGINAL INSTRUCTIONS

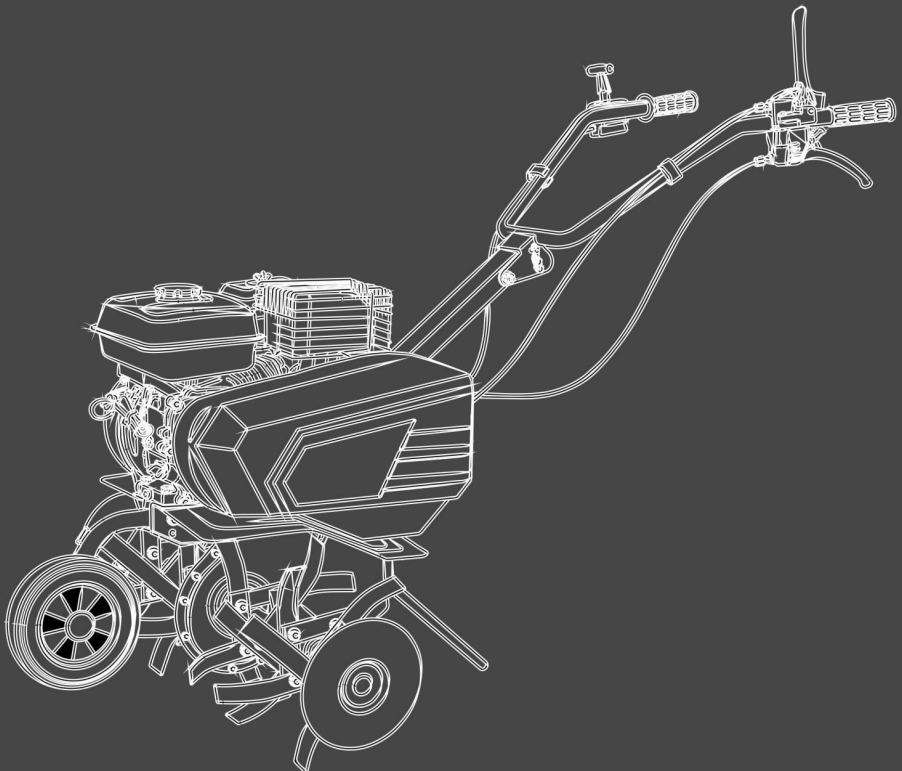

CAUTION: Read the instructions carefully. Be familiar with the controls and the proper use of the equipment

WARNING:

For your safety and safety of others please pay special attention to these precautions:



Read the instruction manual before use



Risk of projections! Keep bystanders at least 15 m away!



Caution: rotating working tool!



Danger: disconnect spark plug wire before servicing unit!



Check oil and fuel before start to use

- That the machine shall always be used in accordance with these manufacturer's instructions the instruction handbook
- The engine shall be stopped when carrying out maintenance and cleaning operations, when changing tools and when being transported by means other than under its own power;
- Some hazards can be met when working on slopes; work slowly by holding firmly the tool. Do not transport the tool on slopes. The hazards can rise when working on difficult soil (stony, hard, etc.). there is a risk to hit some objects, sliding, lose control for the machine which will gives damages. Always inspect the working area before working, and always watch what you are doing.
- The adjustable part of the protective device shall be adjusted to the working depth of the tool so that only that part of the working tool that cuts into the soil remains uncovered. This does not apply to motor hoes.

1) Training

- a) Read the instructions carefully. Be familiar with the controls and the proper use of the equipment;
- b) Never allow children or people unfamiliar with these instructions to use the machine. Local regulations can restrict the age of the operator;
- c) Never work while people, especially children, or pets are nearby;
- d) Keep in mind that the operator or user is responsible for accidents or hazards occurring to other people or their property.

2) Preparation

- a) While working, always wear substantial footwear and long trousers. Do not operate the equipment when barefoot or wearing open sandals;

b) Thoroughly inspect the area where the equipment is to be used and remove all objects which can be thrown up by the machine;

c) **WARNING** – Petrol is highly flammable:

- Store fuel in containers specifically designed for this purpose;
- Refuel outdoors only and do not smoke while refuelling;
- Add fuel before starting the engine. Never remove the cap of the fuel tank or add petrol while the engine is running or when the engine is hot;
- If petrol is spilled, do not attempt to start the engine but move the machine away from the area of spillage and avoid creating any source of ignition until petrol vapours have dissipated;
- Replace all fuel tank and container caps securely;

d) Replace faulty silencers;

e) Before using, always visually inspect to see that the tools are not worn out or damaged. Replace worn out or damaged elements and bolts in sets to preserve balance.

3) Operation

a) Do not operate the engine in a confined space where dangerous carbon monoxide fumes can collect;

b) Work only in daylight or in good artificial light;

c) Always be sure of your footing on slopes;

d) Walk, never run with the machine;

e) For wheeled rotary machines, work across the slopes, never up and down;

f) Exercise extreme caution when changing direction on slopes;

g) Do not work on excessively steep slopes;

h) Use extreme caution when reversing or pulling the machine towards you;

i) Do not change the engine governor settings or overspeed the engine;

j) Start the engine carefully according to manufacturer instructions and with feet well away from the tool(s);

k) Do not put your hands or feet near or under rotating parts;

- l) Never pick up or carry a machine while the engine is running;
- m) Stop the engine:
 - Whenever you leave the machine;
 - Before refuelling;
- n) Reduce the throttle setting during engine shut down and, if the engine is provided with a shut-off valve, turn the fuel off at the conclusion of working;

4) Maintenance and storage

- a) Keep all nuts, bolts and screws tight to ensure the equipment is in safe working condition;
- b) Never store the equipment with petrol in the tank inside a building where fumes can reach an open flame or spark;
- c) Allow the engine to cool before storing in any enclosure;
- d) To reduce the fire hazard, keep the engine, silencer, battery compartment and petrol storage area free of vegetative material and excessive grease;
- e) Replace worn or damaged parts for safety;
- f) If the fuel tank has to be drained, this shall be done outdoors.

Thrown Object Hazard

Objects hit by the rotating tines can be thrown from the tiller with great force and may cause severe injury.

1. Before tilling, clear the tilling area of sticks, large stones, wire, glass etc.
2. Pieces thrown from worn or damaged-tines can cause serious injury.
Always inspect the tines before using the tiller.

Fire and Burn Hazard

Gasoline is extremely flammable and gasoline vapor can explode.

Use extreme care when handling gasoline. Keep gasoline out of reach of children.

1. Refuel in a well-ventilated area with the engine stopped.
2. Allow the engine to cool before refueling. Fuel vapor or spilled fuel may be ignited.

3. The engine and exhaust system becomes very hot during operation and remains hot after stopping. Touching them can cause burn injuries or some materials burn.
4. Avoid touching a hot engine or exhaust system.
5. Allow the engine to cool before performing maintenance or storing the tiller indoors.

Carbon Monoxide Poisoning Hazard

Exhaust contains poisonous carbon monoxide a colorless and odorless gas. Breathing exhaust can cause loss of consciousness and may lead to death.

Operation on Slope

1. When tilling on slopes, keep the fuel tank with less than half oil to minimize fuel spillage.
2. When the tiller walks across the slope, put your effort evenly while walking up and down the slope.
3. Be very careful when changing the direction of the tiller on a slope.
4. Do not use the tiller on a slope of more than 10° .
5. The maximum safe grade angle shown is for reference only and the details should depend on the type of the tool. Before starting the engine, check that the tiller is not damaged and in good condition. For your safety or safety of others, pay special attention when using the tiller up or down hill.

STRUCTURAL REPRESENTATION



1.FORWARD CLUTCH

2.REVERSE CLUTCH
(HMTB52-1 WITHOUT)

3.HANDLE

4.GIRDER

5.BELT COVER

6.OUTER MUDGUARD
(HMTB52-1,HMTB5255-3 WITHOUT)

7.REAR DISC

8.BLADE SET

(HMTB52-1,HMTB5255-3:2SETS)

(HMTB6855-3:3SETS)

(HMTB8365-3:4SETS)

9.FRONT WHEEL

10.ENGINE

11.THROTTLE SWITCH

12.EXTINGUISH SWITCH

ASSEMBLY

1. Open the package and take the machine out carefully!
2. **Install Drag Bar**

Put the drag bar to the hole of the back side of the frame .Fix the screw M8x16 on the side .



3. Install blades :
HMTB52-1,HMTB5255-3 : 2SETS BLADES , 6x M10 Screw ,6xM10 nut

HMTB6855-3: 3SETS BLADES, 8x M10 Screw ,8xM10 nut

HMTB8365-3 : 4SETS BLADES,10x M10 Screw ,10xM10 nut

Connect the blade set and rear disc one by one with M10x45 screws and M10 nuts . Next put the whole blade set to the shaft of the gear box . Tight it with M10x45 and M10 nuts .

(Please make sure that the edges of tines forward to the front wheel).



4. **Install Front Wheel :** Put one M8x45 screw to the inner hole of the frame , inset the front wheel , and fix it with another M8x45 screw .



5. Install the Handle assemble .

- a. Fit Grider to the frame with 4xM8x16 screw .
- b. Take the bolt and pin out of the above Grider , put the Handle above the Grider and fix with bolt and pin .
- c. Fit Throttle switch , Forward clutch , Reverse Clutch(HMTB52-1 without Reverse Clutch) to the Handle .





6. Fit inner mudguard :

Tight left and right inner mudguard with 2pcs M6x12 screw and nut .





7. Install Outer Mudguard :

HMTB52-1 and HMTB5255-3 : without outer mudguard

HMTB6855-2,HMTB8365-2: 2pcs outer mudguard ,

6pcs M6x12 Screw, 6pcs M6 nut

Put outer mudguard above the inner mudguard ,and tight with M6x12 screw .



ADJUSTMENT AND OPERATION

The micro-tiller is suitable for cultivating the sandy soil and clay soil, dry land. Fill the tank with oil and gasoline after reading the engine instructions before using the tiller.

- ◆ Place the tiller on a flat place and turn the oil plug out, then fill the high quality oil on the lower limb of the oil hole.

- ◆ **Front Wheel Adjustment**

Unscrew the bolt , take out the wheel , face it upward during working .



- ◆ **Depth Adjustment**

Adjust the height of the drag bar according the depth of the cultivation. And lock the drag bar tightly with the side screw. M8x16



◆ **The Height of Handle Adjustment**

Adjust the handle up and down to the proper height against the operator's height. Then fix the pin.

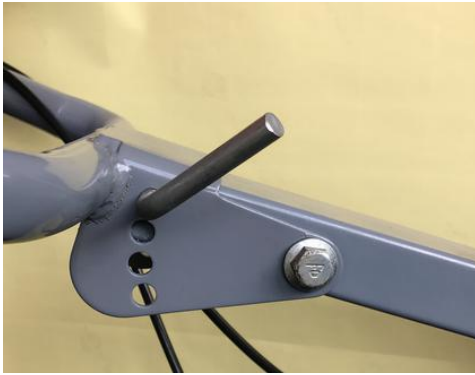

◆ **Start Up and Shut Down**

Make sure the extinguish switch is on the on position before starting up the engine. Make sure the extinguishing switch on the off position if shutting down the engine.



◆ **The Throttle Adjustment**

Make sure the throttle governor turns on the “rabbit” position before starting. Adjust the throttle governor to the proper position according the depth of the cultivation while cultivating.



◆ **Start Up**

Read the engine instructions carefully and master the starting skills before starting.

Pull the starter grip lightly until resistance is felt, then pull briskly. Do not allow the starter grip to snap back against the engine and return it gently to prevent damage to the starter.

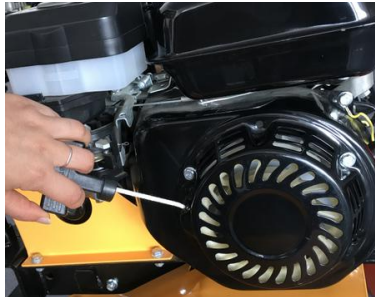

◆ **The Clutch Operation**

Make sure that all the above steps be completed correctly.

When the clutch lever is squeezed, the tiller starts cultivating and reversing (Up clutch is for FORWARD, down clutch is for REVERSE).

HMTB52-1: without Reverse Clutch



SPECIFICATIONS

1. Model: HMTB52-1

Engine: 4-stroke combustion engine

Type: 6.5HP

Displacement: 196cc

Power: 3,5kW, 3600 min⁻¹

Fuel tank: 3.6L

Hoeing tools: 4 cutting elements and two discs

Working width without protection discs: 43cm

Working width with protection discs: 52cm

Diameter of the blade set: 30cm

Rotation speed of the blade set: 142tr / min

Start Mode: Manual Launcher

Safety device: Clutch

Transmission: 1 forward speed

Weight: 40kgs

External dimensions: 1500x580x850

Sound pressure level (LpA): 89.8dB (A) K = 3 dB (A)

Sound power level (LWA): 105 dB (A) (2000/14 / EC)

Vibration: Left Handle/Right Handle: 8.745/11.162m / s², K = 1.5m / s²

2.Model: HMTB5255-3

Engine: 4-stroke combustion engine

Type: 6.5HP

Displacement: 196cc

Power: 3,5kW, 3600 min⁻¹

Fuel tank: 3.6L

Hoeing tools: 4 cutting elements and two discs

Working width without protection discs: 43cm

Working width with protection discs: 52cm

Diameter of the blade set: 30cm

Rotation speed of the blade set: 142tr / min

Start Mode: Manual Launcher

Safety device: Clutch

Transmission: 1 forward speed, 1 reverse speed

Weight: 41kgs

External dimensions: 1500x580x850

Sound pressure level (LpA): 89.8dB (A) K = 3 dB (A)

Sound power level (LWA): 105 dB (A) (2000/14 / EC)

Vibration: left handle / right handle: 8.745/11.162 m/s², K = 1.5 m / s²

3.Model: HMTB6855-3

Engine: 4-stroke combustion engine

Type: 6.5HP

Displacement: 196cc

Power: 3,5kW, 3600 min⁻¹

Fuel tank: 3.6L

Hoeing tools: 6 cutting elements and two discs

Working width without protection discs: 59cm

Working width with protection discs: 68cm

Diameter of the blade set: 30cm

Rotation speed of the blade set: 142tr / min

Start Mode: Manual Launcher

Safety device: Clutch

Transmission: 1 forward speed, 1 reverse speed

Weight: 43kgs

External dimensions: 1500x680x850

Sound pressure level (LpA): 89.8dB (A) K = 3 dB (A)

Sound power level (LWA): 105 dB (A) (2000/14 / EC)

Vibration: left handle / right hand grip:8.745/11.162m / s²,K=1.5 m / s²

4.Model: HMTB8365-3

Engine: 4-stroke combustion engine

Type: 6.5HP

Displacement: 196cc

Power: 3,5kW, 3600 min⁻¹

Fuel tank: 3.6L

Hoeing tools: 8 cutting elements and two discs

Working width without protection discs: 74cm

Working width with protection discs: 85cm

Diameter of the blade set: 30cm

Rotation speed of the blade set: 142tr / min

Start Mode: Manual Launcher

Safety device: Mechanical clutch

Transmission: 1 forward speed, 1 reverse speed

Weight: 52.5kgs

External dimensions: 1500x850x850

Sound pressure level (LpA): 89.8dB (A) K = 3 dB (A)

Sound power level (LWA): 105 dB (A) (2000/14 / EC)

Vibration: left handle / right handle:8.745/11.162m / s², K = 1.5 m/s²

MAINTENANCE

Please note that maintenance operations are scheduled for normal operating conditions. If the operation of tiller takes place under other conditions, we recommend that you communicate with your dealer to deal with the machine.

1. Turn off the engine and disconnect the spark plug prior to maintenance operations.
2. Allow the engine and exhaust system to cool to avoid burns from contacting with hot parts.
3. It is important to keep safety gloves in the event that you need to manipulate the blades.
4. Wipe the dirt things on the machine.
5. Remove the fuel from tiller if this is to be stored for longer than a month.
6. It is appropriate to check that all bolts and nuts have not been loosened after each session.
7. The guard should be fixed after assembling and it should not be removed or adjusted during use and maintenance.

PARTSaaaaaa		Each use	First mon/20 hours	First three months / 50 hours	First eight months / 100 hours	Each annual/300 hours
Engine Lubricant	Checking the level	●			●	
	Change		●		●	
Air Filter	Checkout	●				
	Clean			●		
	Substitution					●
Spark	Clean and reset				●	
	Substitution					●
Muffler	Clean				●	
Fuel tank sediment	Clean					●
Fuel tank filter and	Clean					●
Fuel inlet	Checking and replacement if necessary					●



Déclaration de conformité

BUILDER SAS

ZI, 32 rue aristide Bergès – 31270 Cugnaux - France

Declares that the machinery designated below:

Gasoline Tiller

HMTB5255-3

HMTB8365-3

Serial number : 20200808945-20200809169

20200809170-20200809294

Complies with the provisions of the Directive "machinery" 2006/42 / EC

and the national regulations transposing it;

Also complies with the following European directives:

CEM Directive: 2014/30/EU

Emission directive (EU): 2016/1628

Noise emission Directive 2000/14/EC Annex V and Directive 2005/88/EC

Also complies with European standards, national standards and

technical provisions following:

EN 709:1997+A4: 2009/AC: 2012

EN ISO 14982:2009

Fait à Cugnaux, le 16/07/2020

Philippe MARIE / PDG

HYUNDAI

WARRANTY

The manufacturer guarantees the product against defects in material and workmanship for a period of 2 years from the date of the original purchase. The warranty only applies if the product is for household use. The warranty does not cover breakdowns due to normal wear and tear.

The manufacturer agrees to replace parts identified as defective by the designated distributor. The manufacturer does not accept responsibility for the replacement of the machine, in whole or in part, and/or ensuing damage.

The warranty does not cover breakdowns due to:

- insufficient maintenance.
- abnormal assembly, adjustment or operations of the product.
- parts subject to normal wear and tear.

The warranty does not extend to:

- shipping and packaging costs.
- using the tool for a purpose other than that for which it was designed.
- the use and maintenance of the machine done in a manner not described in the user manual.

Due to our policy of continuous product improvement, we reserve the right to alter or change specifications without notice. Consequently, the product may be different from the information contained therein, but a modification will be undertaken without notice if it is recognized as an improvement of the preceding characteristic.

READ THE MANUAL CAREFULLY BEFORE USING THE MACHINE.

When ordering spare parts, please indicate the part number or code, you can find this in the spare parts list in this manual. Keep the purchase receipt; without it, the warranty is invalid. To help you with your product, we invite you to contact us by phone or via our website:

- **+33 (0)9.70.75.30.30**
- **<https://services.swap-europe.com/contact>**

You must create a "ticket" via the web platform.

- Register or create your account.
- Indicate the reference of the tool.
- Choose the subject of your request.
- Describe your problem.
- Attach these files: invoice or sales receipt, photo of the identification plate (serial number), photo of the part you need (for example: pins on the transformer plug which are broken).



PRODUCT FAILURE

WHAT TO DO IF MY MACHINE BREAKS DOWN?

If you bought your product in a store:

- a) Empty the fuel tank.
- b) Make sure that your machine is complete with all accessories supplied, and clean! If this is not the case, the repairer will refuse the machine.

Go to the store with the complete machine and with the receipt or invoice.

If you bought your product on a website:

- a) Empty the fuel tank.
- b) Make sure that your machine is complete with all accessories supplied, and clean! If this is not the case, the repairer will refuse the machine.
- c) Create a SWAP-Europe service ticket on the site: <https://services.swap-europe.com> When making the request on SWAP-Europe, you must attach the invoice and the photo of the nameplate (serial number).
- d) Contact the repair station to make sure it is available before dropping off the machine.

Go to the repair station with the complete machine packed, accompanied by the purchase invoice and the station support sheet downloadable after the service request is completed on the SWAP-Europe site

For machines with engine failure from manufacturers BRIGGS & STRATTON, HONDA and RATO, please refer to the following instructions.

Repairs will be done by approved engine manufacturers of these manufacturers, see their site:

- <http://www.briggsandstratton.com/eu/fr>
- <http://www.honda-engines-eu.com/fr/service-network-page;jsessionid=5EE8456CF39CD572AA2AEEDFD290CDAE>
- <https://www.rato-europe.com/it/service-network>

Please keep your original packaging to allow for after-sales service returns or pack your machine with a similar cardboard box of the same dimensions.

For any question concerning our after-sales service you can make a request on our website <https://services.swap-europe.com>

Our hotline remains available at +33 (9) 70 75 30 30.



WARRANTY EXCLUSIONS

THE WARRANTY DOES NOT COVER:

- Start-up and setting up of the product.
- Damage resulting from normal wear and tear of the product.
- Damage resulting from improper use of the product.
- Damage resulting from assembly or start-up not in accordance with the user manual.
- Breakdowns related to carburetion beyond 90 days and fouling of carburetors.
- Periodic and standard maintenance events.
- Actions of modification and dismantling that directly void the warranty.
- Products whose original authentication marking (brand, serial number) has been degraded, altered or withdrawn.
- Replacement of consumables.
- The use of non-original parts.
- Breakage of parts following impacts or projections.
- Accessories breakdowns.
- Defects and their consequences linked to any external cause.
- Loss of components and loss due to insufficient screwing.
- Cutting components and any damage related to the loosening of parts.
- Overload or overheating.
- Poor power supply quality: faulty voltage, voltage error, etc.
- Damages resulting from the deprivation of enjoyment of the product during the time necessary for repairs and more generally the costs related to the immobilization of the product.
- The costs of a second opinion established by a third party following an estimate by a SWAP-Europe repair station
- The use of a product which would show a defect or a breakage which was not the subject of an immediate report and/or repair with the services of SWAP-Europe.
- Deterioration linked to transport and storage*.
- Launchers beyond 90 days.
- Oil, petrol, grease.
- Damages related to the use of non-compliant fuels or lubricants.

* In accordance with transport legislation, damage related to transport must be declared to carriers within 48 hours maximum after observation by registered letter with acknowledgement of receipt.

This document is a supplement to your notice, a non-exhaustive list.

Attention: all orders must be checked in the presence of the delivery person. In case of refusal by the delivery person, it you must simply refuse the delivery and notify your refusal.

Reminder: the reserves do not exclude the notification by registered letter with acknowledgement within 72 hours.

Information:

Thermal devices must be wintered each season (service available on the SWAP-Europe site). Batteries must be charged before being stored.

HYUNDAI

POWER PRODUCTS

For Inquiries, please contact:

BUILDER SAS

32, rue Aristide Bergès Z1 31270 Cugnaux, France

Tél. : +33 (0) 5.34.502.502 Fax : +33 (0) 5.34.502.503

<http://www.hyundaipower-fr.com/>

Fabriqué en République Populaire de Chine (PRC)